

# Circuit Components

## Lesson 4

### 4.1 Amplifier Fundamentals

The role of an amplifier is to produce an output which is an enlarged reproduction of the features of the signal fed into the input. The increase in signal by an amplifier is called **gain**. We can amplify voltage, current, or power. **Note: Resistance IS NOT amplified by a amplifier.**

A device with gain has the property of amplification.

Vacuum Tube



Transistor

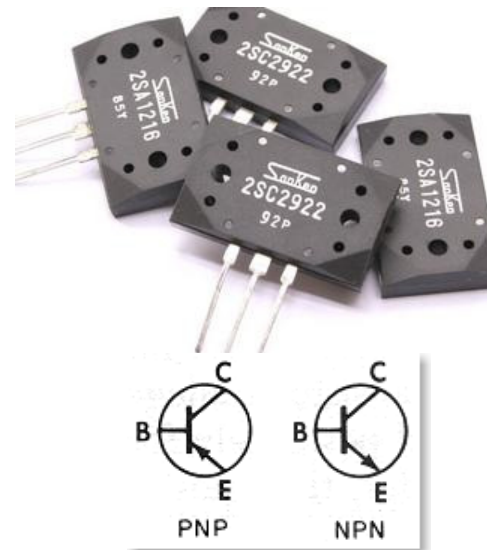

Integrated Circuit (IC)

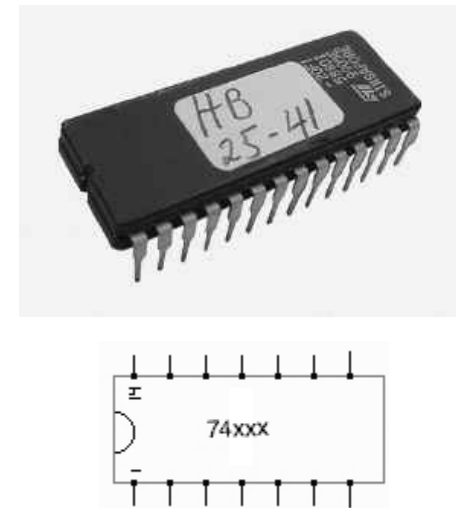

# Circuit Components

## Lesson 4

### 4.1 Amplifier Fundamentals

**Audio frequency** or **AF amplifiers** are used to amplify AC signals in the audio frequency spectrum, from about 20 Hz to 20 kHz.

To increase the level of very weak signals from a microphone you would use a audio (AF) amplifier.

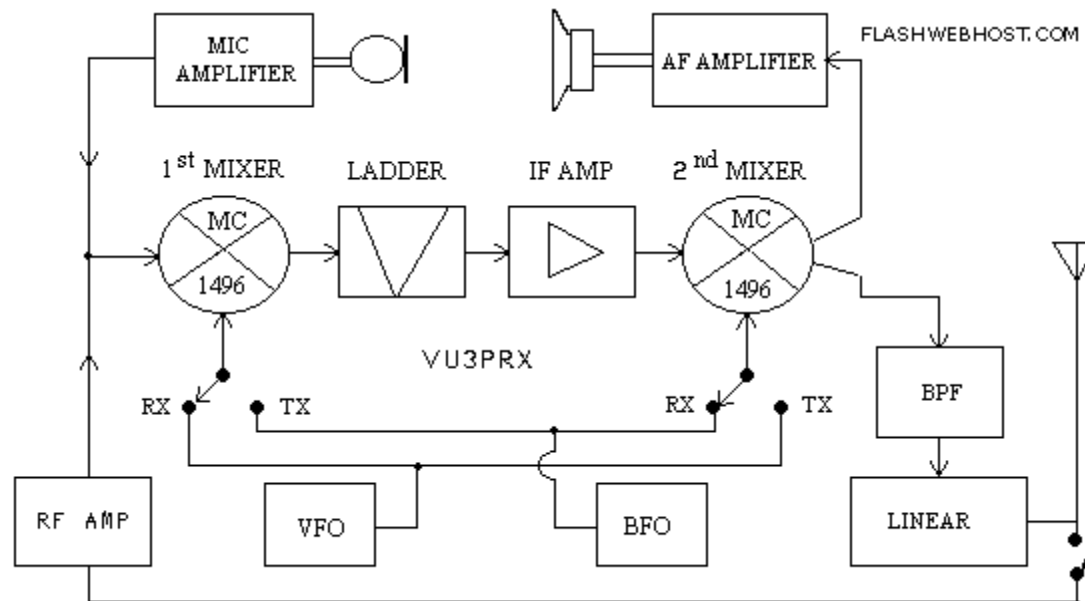

# Circuit Components

## Lesson 4

### 4.1 Amplifier Fundamentals

**Radio frequency** or **RF amplifiers** are used for signals above 20 kHz. You will encounter both types of amplifiers when you deal with receivers and transmitters.

To increase the level of very weak radio signals from an antenna, you would use a RF amplifier

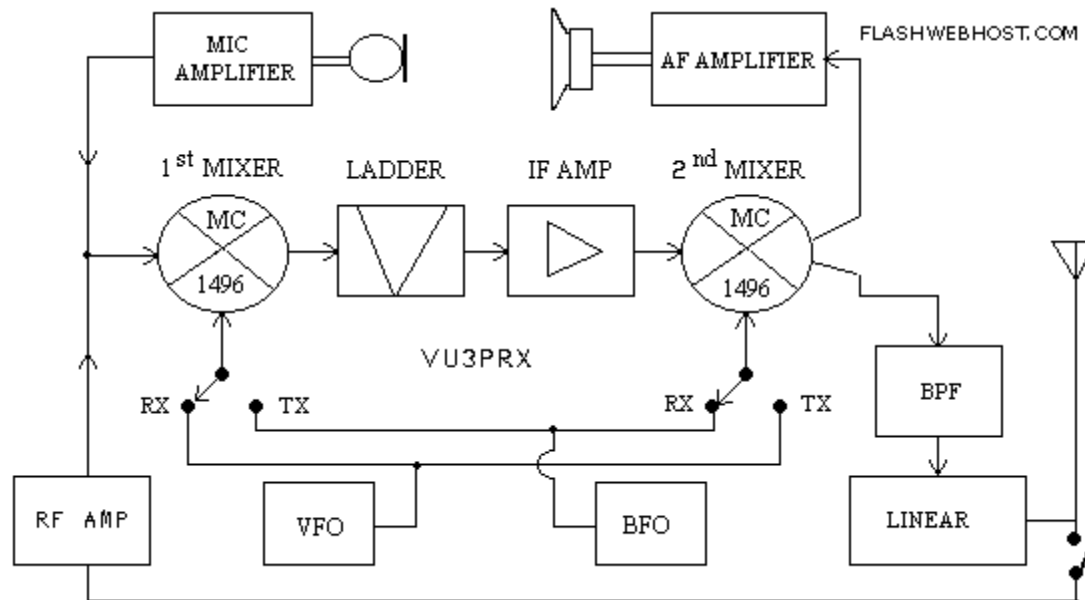

# Circuit Components

## Lesson 4

### 4.2 Diode Fundamentals

The electrodes of a semiconductor diode are known as **anode** and **cathode**.

In a semiconductor diode, electrons flow from **cathode to anode**. In order for a diode to conduct, it must be **forward-biased**.

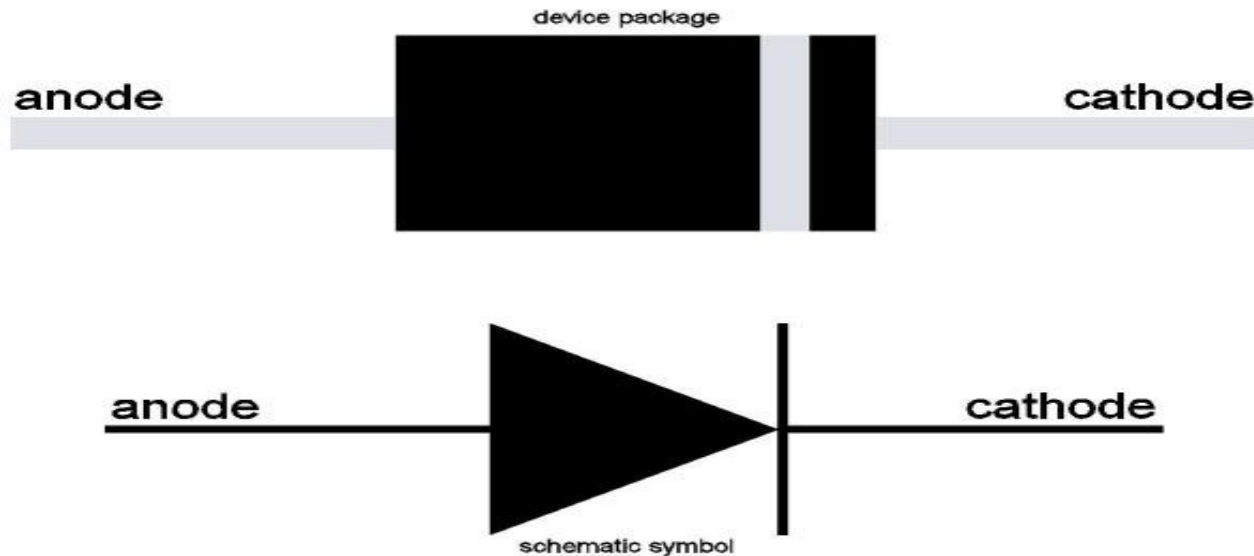

# Circuit Components

## Lesson 4

### 4.2 Diode Fundamentals

If alternating current is applied to the anode of a diode, at the cathode of the diode you would expect to see **pulsating direct current**.

The action of changing alternating current (AC) to direct current (DC) is called **rectification**.

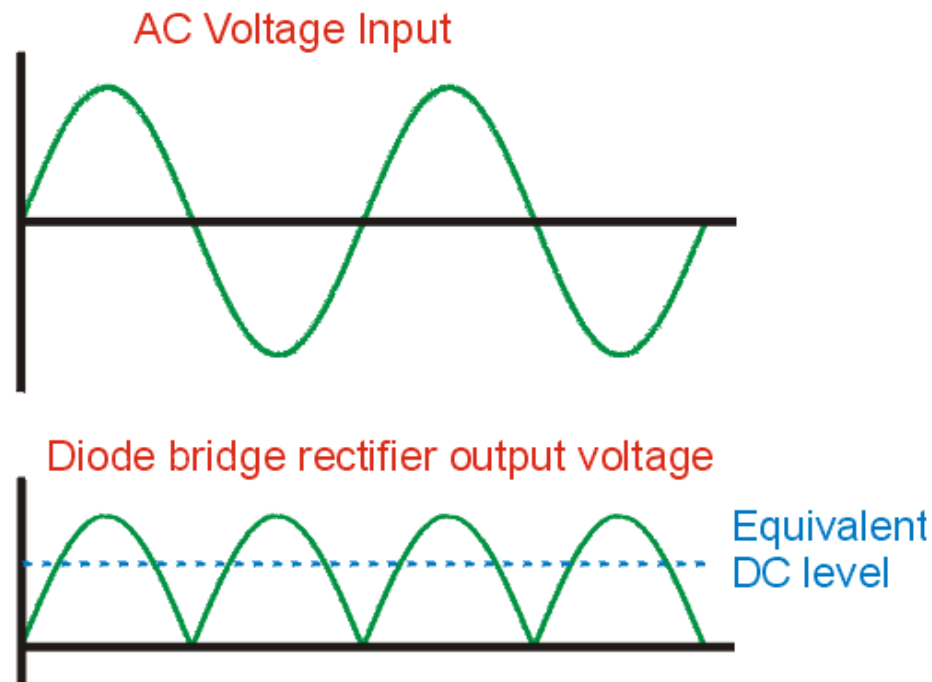

# Circuit Components

## Lesson 4

### 4.2 Diode Fundamentals

Zener diodes are used to maintain a fixed voltage. They are designed to 'breakdown' in a reliable and non-destructive way so that they can be used **in reverse** to maintain a fixed voltage across their terminals. The diagram shows how they are connected, with a resistor in series to limit the current.

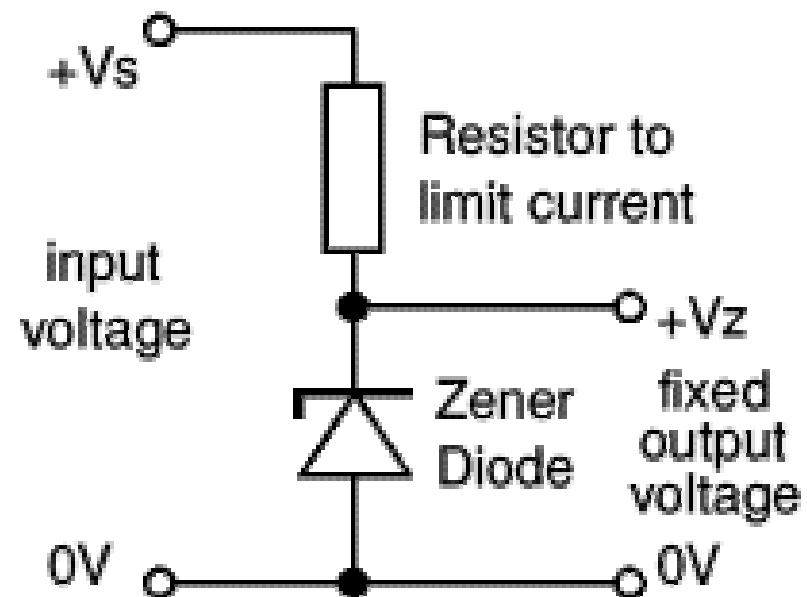
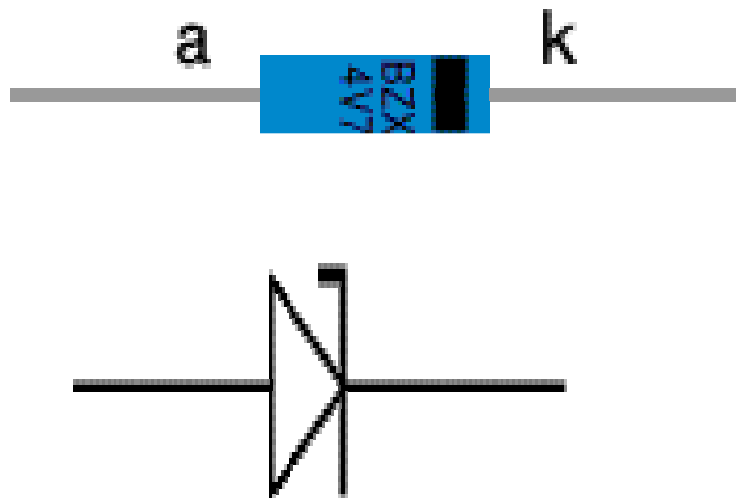

# Circuit Components

## Lesson 4

### 4.2 Diode Fundamentals

One important application for diodes is recovering information from transmitted signals. This is referred to as **demodulation**.

The AM detector or demodulator includes a capacitor at the output. Its purpose is to remove any radio frequency components of the signal at the output.

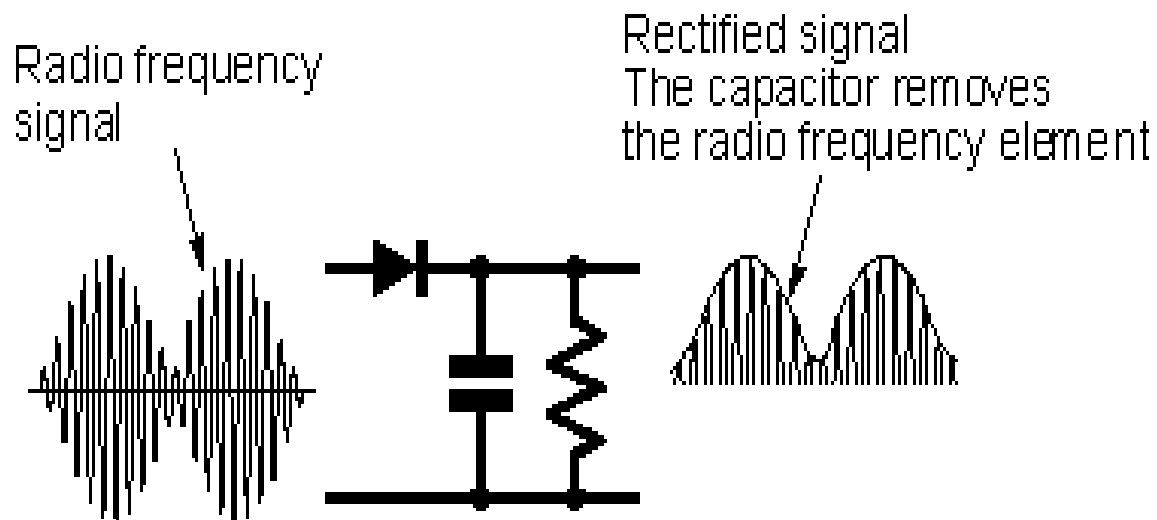

# Circuit Components

## Lesson 4

### 4.2 Diode Fundamentals

Light Emitting Diodes (LEDs) are solid-state semiconductor devices that convert electrical energy directly into light. LED "cold" generation of light leads to high efficacy because most of the energy radiates within the visible spectrum. Because LEDs are the solid-state devices, they can be extremely small and durable; they also provide longer lamp life than other sources.

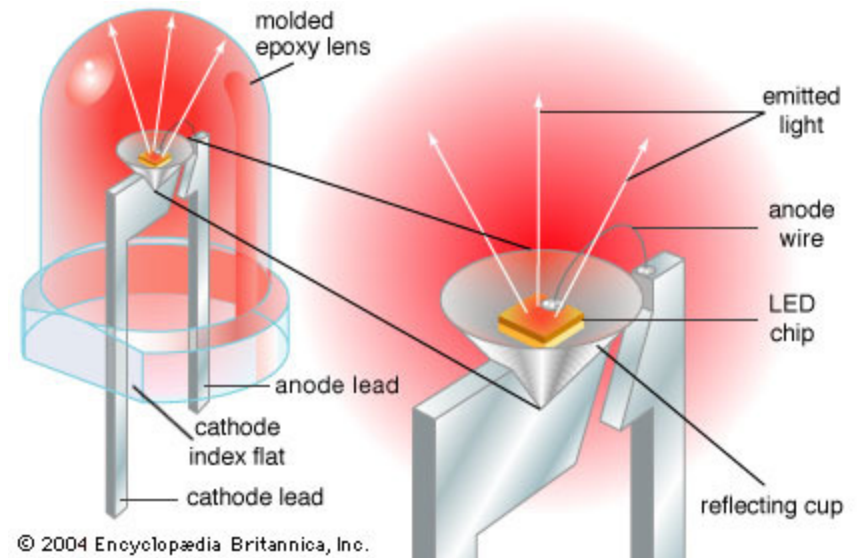

LEDs are made of various semiconducting compounds, depending on the desired colour output. Infrared and red LEDs generally use a gallium, aluminum, and arsenide compound. Orange and yellow LEDs most often use gallium, aluminum, and either indium or phosphorus. Green and blue LEDs typically use either silicon and carbon, or gallium and nitrogen.



# Circuit Components

## Lesson 4

### 4.3 Bipolar Transistor Fundamentals

The basic semiconductor amplifying device is the **transistor**

A *Bipolar Transistor* essentially consists of a pair of *PN Junction Diodes* that are joined back-to-back.

This forms a sort of a sandwich where one kind of semiconductor is placed in between two others.

There are therefore two kinds of Bipolar sandwich, the ***NPN*** and ***PNP*** varieties. The three layers of the sandwich are conventionally called the ***Collector***, ***Base***, and ***Emitter***.

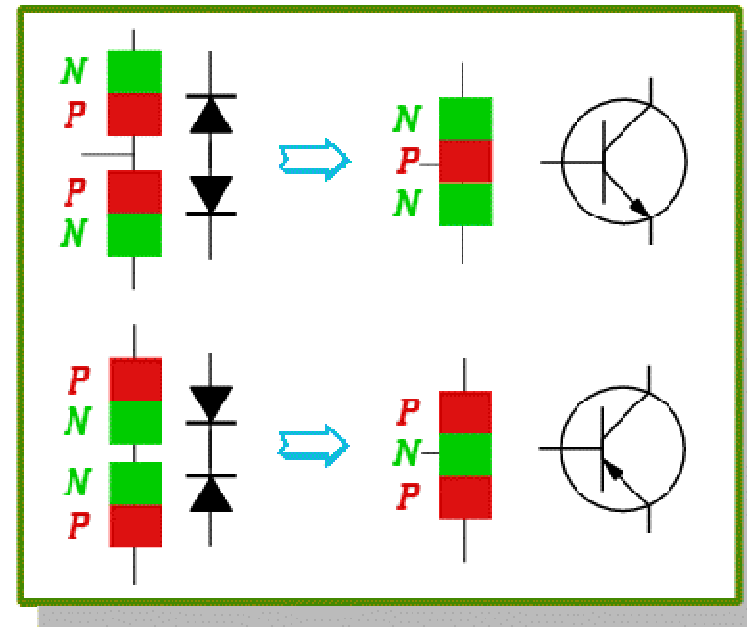

# Circuit Components

## Lesson 4

### 4.3 Bipolar Transistor Fundamentals

In a bipolar transistor the **base** compares closest to the **control grid** of a triode vacuum tube

In a bipolar transistor the **collector** compares closest to the **plate** of a triode vacuum tube

In a bipolar transistor the **emitter** compares closest to the **cathode** of a triode vacuum tube

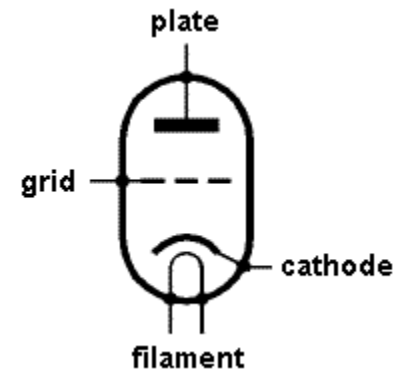
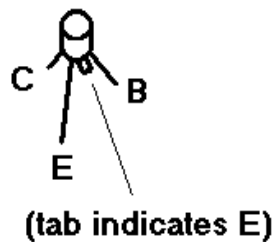
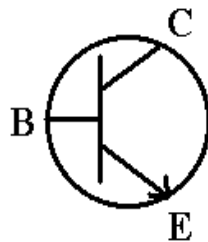
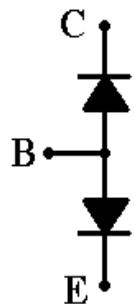

# Circuit Components

## Lesson 4

### 4.3 Bipolar Transistor Fundamentals

A **PNP transistor** can amplify a small signal using low voltages. If a low level signal is placed at the input to a transistor, a higher level of signal is produced at the output lead. This effect is known as **amplification**

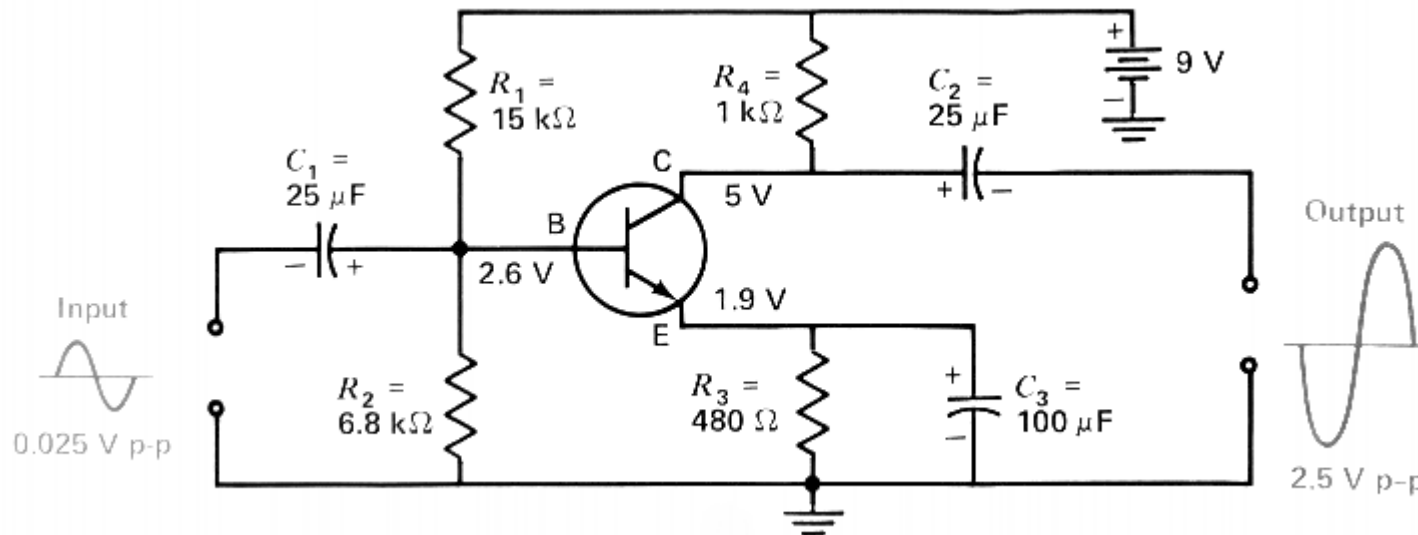

# Circuit Components

## Lesson 4

### 4.4 Field Effect Transistor Fundamentals

A field effect transistor has only two layers of semiconductor material, one on top of the other. Electricity flows through one of the layers, called the channel. A voltage connected to the other layer, called the gate, interferes with the current flowing in the channel. Thus, the voltage connected to the gate controls the strength of the current in the channel. There are two basic varieties of field effect transistors-the junction field effect transistor (JFET) and the metal oxide semiconductor field effect transistor (MOSFET).

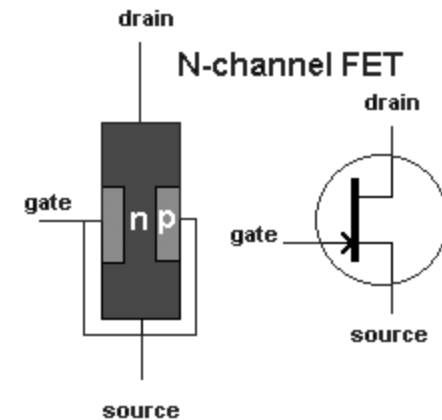

In a field effect transistor, the **gate** controls the conductance of the channel, the **source** is where the charge carriers enter the channel and the **drain** is where the charge carriers leave the channel.

The control element in a field effect transistor is the **gate**.

# Circuit Components

## Lesson 4

### 4.5 Triode Vacuum Tube Fundamentals

A vacuum tube consists of arrangements of [electrodes](#) in a [vacuum](#) within an insulating, temperature-resistant envelope.

The electrodes are attached to leads which pass through the envelope via an air tight seal.

When hot, the filament releases [electrons](#) into the vacuum: a process called [thermionic emission](#).

The resulting negatively-charged cloud of electrons is called a [space charge](#). These electrons will be drawn to a metal plate inside the envelope, if the plate (also called the [anode](#)) is positively charged relative to the filament (or [cathode](#)). The result is a flow of electrons from filament to plate.

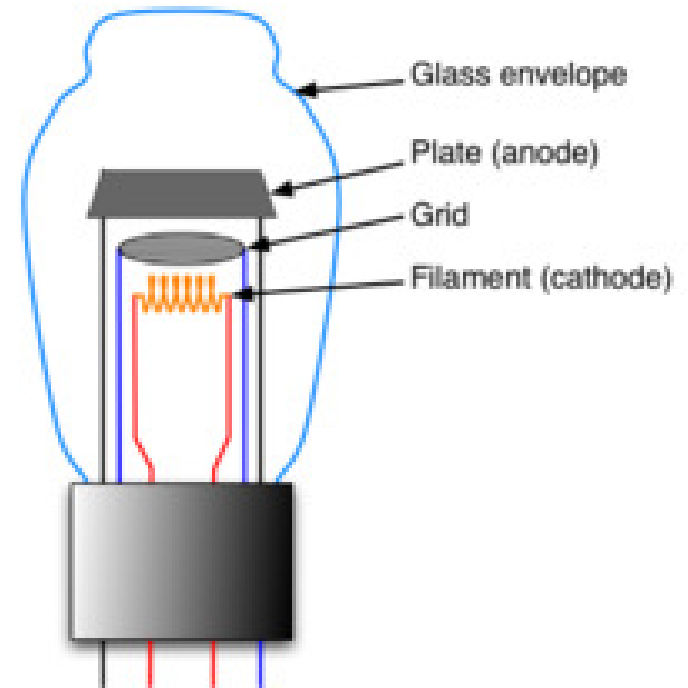

# Circuit Components

## Lesson 4

### 4.5 Triode Vacuum Tube Fundamentals

#### Vacuum Tube verses Transistor

- triode vacuum tube can be used instead of a transistor to handle **higher power**
- vacuum tube can amplify small signals but must use high voltages.
- both tubes and transistors can amplify signals

#### In a vacuum tube;

- the electrode that is operated at the highest positive potential is the **plate**.
- the electrode that is usually a cylinder of wire mesh is the **grid**.
- the electrode that is farthest away from the plate is the **filament**.
- the electrode that emits electrons is the **cathode**.

# Circuit Components

## Lesson 4

### 4.6 Resistor Colour Codes, Tolerances

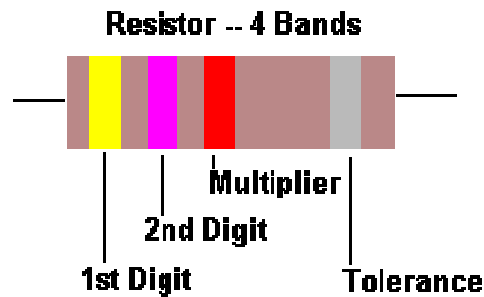

Band Color	Digit	Multiplier	Tolerance
Black	0	1	---
Brown	1	10	±1%
Red	2	100	±2%
Orange	3	1,000	±3%
Yellow	4	10,000	±4%
Green	5	100,000	---
Blue	6	1,000,000	---
Violet	7	10,000,000	---
Gray	8	100,000,000	---
White	9	---	---
Gold	---	0.1	±5%
Silver	---	0.01	±10%
None	---	---	±20%

0	1	2	3	4	5	6	7	8	9
Bad	Booze	Rots	Our	Young	Guts	But	Vodka	Goes	Well
Black	Brown	Red	Orange	Yellow	Green	Blue	Violet	Gray	White

# Circuit Components

## Lesson 4

### **4.6 Resistor Colour Codes, Tolerances, Temperature Coefficient**

The color code chart is applicable to most of the common four band and five band resistors. Five band resistors are usually precision resistors with tolerances of 1% and 2%. Most of the four band resistors have tolerances of 5%, 10% and 20%.

The color codes of a resistor are read from left to right, with the tolerance band oriented to the right side. Match the color of the first band to its associated number under the digit column in the color chart. This is the first digit of the resistance value. Match the second band to its associated color under the digit column in the color chart to get the second digit of the resistance value.

Match the color band preceding the tolerance band (last band) to its associated number under the multiplier column on the chart. This number is the multiplier for the quantity previously indicated by the first two digits (four band resistor) or the first three digits (five band resistor) and is used to determine the total marked value of the resistor in ohms.



# Circuit Components

## Lesson 4

### 4.6 Resistor Colour Codes, Tolerances, Temperature Coefficient

To determine the resistor's tolerance or possible variation in resistance from that indicated by the color bands, match the color of the last band to its associated number under the tolerance column. Multiply the total resistance value by this percentage.

For example, the first resistor shown at the top of this page has a resistance of  $(47 \times 100) = 4700$  ohms. The tolerance is plus or minus  $(10\% \times 4700) =$  plus or minus 470 ohms. The second resistor has a resistance of  $(470 \times 1) = 470$  ohms. The tolerance is plus or minus  $(2\% \times 470) =$  plus or minus 9.4 ohms.

# Circuit Components

## Lesson 4

### 38.2.00 Circuit diagrams

